

HALF TIME OVEN® 2X ULTRASPEED OVEN® 4X Use and Care Manual

High Speed Convection Microwave Ovens

**Cooks Delicious Food Like a Gas or Electric Oven
Same Taste, Appearance and Browning
But in a Fraction of the Time**

Four Cooking Modes

Cooks and browns like a gas or electric oven, but in a fraction of the time. Use the regular cooking time from any cookbook or directions on any food package. The electronic control will automatically calculate the high speed cooking time.

HIGH SPEED
2X/4X

2X Models - Cooks two times faster than a gas or electric oven. Reduces cooking time 50%.

4X Models - Cooks four times faster than a gas or electric oven. Reduces cooking times 75%.

COMPLETE
MEAL

Complete Meal - Cook meat, poultry or fish, potatoes or rice and vegetables or casseroles all at the same time. No need to cook items separately.

CONVECTION

Convection - Cooks with Turbo powered Convection Heat, plus some Microwave Energy for speed.

MICROWAVE

Microwave - Cooks and Reheats with Microwave Energy plus Speed Defrost and Defrost by Weight.

Easy to Use:

1. Set Temperature
2. Set Time
3. Press Start

CONTENTS

Precautions to Avoid Possible exposure to Excessive Microwave Energy	2	Instant Action Pads	13
Safety Instructions	2-3	Baked Potato Setting	
Installation-Oven START-UP	4	Popcorn Setting	
Oven Features-Specifications	5	Beverage / Soup Setting	
Control Panel	6	Setting Defrost by Weight	14
Setting The Clock	7	Care & Maintenance	15
Using the Add Time Pad	7	Cleaning	
Setting High Speed Mode	8	Outside Surfaces	
Automatic Pre-Heat	8	Interior Surfaces	
Set Time and Temperature	9	Replacing Oven Light Bulb	
Using Special Trays	10	Service	15-16
Arranging Tray for Complete Meal	10	Before Calling Service Chart	
Complete Meal Mode	11	How To Obtain Service	
Setting Convection Mode	11	Cooking Charts	
Setting Microwave Time and Power	12	High Speed Cooking Chart	17-19
Two Stage Cooking	12	Complete Meal Type A	20
Setting Speed Defrost	13	Complete Meal Type B	21-22
		Convection	23-25
		Grill Rack Cooking	26
		Microwave	27-28
		Reheating	29-31
		Defrosting	32-33
		Warranty	On Back Cover

Half Time Oven, Inc. Warranty Registration	
A Warranty registration card is packed inside the oven. Please fill in the card and mail it to us for proper warranty registration. If you move register your new address by writing to us at the address below. The model number and serial number are found on the rating plate which is located on the front door frame. Write this information below for a handy reference when inquiring about warranty service for your oven.	
TO:	DATE PURCHASED _____
Half Time Oven, Inc.	MODEL NUMBER _____
P.O. Box 6066	SERIAL NUMBER _____
West Palm Beach, FL 33405	

PRECAUTIONS TO AVOID POSSIBLE EXPOSURE TO EXCESSIVE MICROWAVE ENERGY

- A. **Do not** attempt to operate this oven with the door open since open-door operation can result in harmful exposure to microwave energy. It is important not to defeat or tamper with the safety interlocks.
- B. **Do not** place any object between oven front face and the door or allow soil or cleaner residue to accumulate on sealing surfaces.
- C. **Do not** operate the oven if it is damaged. It is particularly important the oven door close properly and that there is no damage to the (1) DOOR (*BENT*), (2) Hinges and latches (*broken or loosened*), (3) door seals and searing surfaces.
- D. The oven should not be adjusted or repaired by anyone except professionally qualified service personnel.

SAVE THESE INSTRUCTIONS IMPORTANT SAFETY INSTRUCTIONS

When using electrical appliances, basic safety precautions should be followed, including the following:

WARNING - To reduce the risk of burns, electrical shock, fire, injury to persons or exposure to excessive microwave energy:

1. **READ ALL THE INSTRUCTIONS BEFORE USING THE APPLIANCE.**
2. Read and follow the specific "Precautions" to avoid possible exposure to excessive microwave energy found above.
3. This appliance must be grounded and properly polarized. Connect only to a properly grounded and polarized outlet. See "Grounding Instructions" on page 3.
4. Install or locate this appliance only in accordance with the installation instructions described in this manual.
5. Some products such as whole eggs and sealed containers, such as closed glass jars, may explode and should not be heated in this oven.
6. Use this appliance only for its intended use as described in the manual. Do not use corrosive chemicals or vapors in this appliance. This type of oven is specifically designed to heat, cook, dry, or defrost food. It is not designed for industrial, laboratory, or commercial use.
It is intended for the home use only. Do not use for drying clothes, linens, newspaper or similar non-food type items.
7. Make sure that all persons using this appliance, especially children, are closely supervised and properly instructed on how to use this appliance.
8. **Do not** operate this appliance if it has a damaged cord or plug, if it is not working properly, or if it has been damaged or dropped.
9. This appliance should be serviced only by qualified service Personnel. Contact the nearest authorized service facility for examination, repair or replacement.
DO NOT ATTEMPT to service or repair this appliance.
10. **Do not** cover or block any opening on the appliance. **Do not** store items on top of the oven if there are louvers on top of oven.
11. **Do not** store this appliance outdoors, do not use this product near water, for example, near a kitchen sink, in a wet basement, or near a swimming pool and the like.
12. **Do not** immerse cord or plug in water.
13. Keep cord away from heated surfaces.
14. **Do not** let cord hang over edge of table or counter.
15. When cleaning surfaces of door, use only mild, nonabrasive soaps or detergents applied with a sponge or soft cloth.
16. To reduce the risk of fire in the oven cavity:
 - a. **Do not** overcook food, especially starchy items such as potatoes and fatty items such as bacon, Carefully attend appliance if paper, plastic, or other combustible materials are placed inside the oven to facilitate cooking.
 - b. **Do not** use plastic or paper in High Speed, Complete Meal, Convection, Grill, Baked Potato or Cake modes.
 - c. If materials inside the oven should ignite, keep oven door closed, turn oven off, and disconnect the power cord, or shut off power at fuse or circuit breaker panel.
 - d. Remove wire twist ties from paper or plastic bag before placing bag in oven.
 - e. **Do not** use the cavity for storage purposes. **Do not** leave paper products, cooking utensils, or food in the cavity when not in use.
 - f. **Do not** put metal inside the oven in the microwave mode. Use only as described in the manual or cookbook supplied with this oven.
17. Use only cooking utensils and accessories made for use in the microwave and specifically described in this manual. Use aluminum foil only as directed in this book.

(continued on page 3)

IMPORTANT SAFETY INSTRUCTIONS

18. In the ½ Time, Complete Meal and Convection modes use glass, metal or ceramic utensils which are "Oven Safe". In the microwave mode use only cooking utensils and accessories made for use in the microwave oven. Use aluminum foil only as directed in this book. **Do not** use outdoors.
19. **Do not** pop popcorn in anything other than a microwave oven popper unless it is a specially treated bag labeled: "Microwave popcorn intended for use in the microwave". **Never** use brown paper bags, glass or plastic bowls, or other unsuitable containers to pop popcorn. To avoid scorching and burning, remove popcorn after popping has slowed to two or three seconds between pops. Prolonged popping can cause smoking from overheated oil, breakage of dishes, damage to oven and eventually a fire.
20. **Do not** remove the outer case or any shields inside the oven cavity.
21. **Do not** remove the outer case or any shields inside the oven cavity.
22. Briskly stir liquids or pureed baby food before heating and reheating to incorporate air. This prevents abrupt boil overs that sometimes occur after air-depleted liquids are heated, especially in tall, narrow containers.
23. Liquids, such as water, coffee, or tea are able to be overheated beyond the boiling point without appearing to be boiling. Visible bubbling or boiling when the container is removed from the microwave oven is not always present. This could result in very hot liquids Suddenly Boiling Over when the container is disturbed or a utensil is inserted into the liquid.
24. **Do not** fry or deep fat fry in the microwave oven. Hot oil can splatter and result in skin burns.
25. **PLASTIC WRAP:** Use only in the microwave mode. Use only those types designed for microwave oven use and avoid forming an air-tight seal. Fold back a small corner or cut a slit to allow steam to escape. Use pot holders with plastic wrap-covered utensils.
26. **ALWAYS** use pot-holders when handling dishes or food in the ½ Time, Complete Meal and Convection mode.
27. Stay near the appliance while it is in use and check cooking progress frequently. Leaving the appliance unattended may result in overcooked food and a possible fire in you oven.
28. When heating a liquid, like soup or beverages, up to a boiling point, do not take it out of the oven immediately. Wait 30 seconds before removing to avoid spilling a hot or scalding liquid.
29. After heating up baby feeding bottles the content should be shaken and the liquid temperature should be checked before feeding, in order to avoid feeding hot or scalding liquid.

SAVE THESE INSTRUCTIONS MICROWAVE TIPS TO AVOID OVEN DAMAGE

Do not operate microwave oven when empty or with empty utensils.

Never use sharp-edged utensils in or near the oven.

Use **ALUMINUM FOIL** only as directed in this book or other special microwave cookbooks. Small strips of foil on meats are helpful in shielding microwaves to prevent overcooked areas. Low-sided aluminum foil pans, such as TV dinner trays, may be used. Use care to keep aluminum foil at least 1 inch away from oven walls, door or top. Metal placed closer than 1-inch from interior surfaces can cause arcing (*electrical sparks*). If arching occurs, stop microwave and remove foil.

PREVENT BURSTING OR EXPLOSION FROM FOOD AND CONTAINERS

Pierce microwavable plastic bags and pouches for frozen foods before heating. Pierce foods with heavy skins such as potatoes, whole squash, apples and chestnuts before cooking. Piercing allows steam to escape and eliminates pressure build-up.

CONTAINERS WITH RESTRICTED OPENINGS such as narrow-necked pop bottles or salad dressing bottles should never be placed in the microwave for either defrosting or heating. These can explode, even if the top has been removed, when heat has built up in the lower portion of the container.

RAW EGGS IN THE SHELL OR HARD COOKED EGGS should never be microwaved. Eggs heat so quickly that pressure build-up might not be avoided, and an explosion could occur.

DO NOT USE RECYCLED PAPER PRODUCTS when Microwaving. They may contain small metal fragments which could ignite,

INSTALLATION

INSTALLATION

This oven was carefully packed and shipped in good condition. If you find shipping damages, notify the dealer immediately.

Remove all packing materials both outside and inside the oven before using it.

This High Speed Oven was designed for household use only. It is not intended for commercial or Industrial use.

The oven requires free movement of air for proper operation. **DO NOT BLOCK AIR VENTS** located on the back underneath, or sides of the oven.

Do not remove the feet from the bottom of the oven. Only models numbers with a BI or OTR suffix can be built-in. All other models must be installed on the counter top

POWER SUPPLY & GROUNDING INSTRUCTIONS

This appliance must be grounded. In the event of an electrical short circuit, grounding reduces the risk of electric shock by providing an escape wire for the electric current.

This appliance is equipped with a grounding plug. Counter top models must be plugged into a separate 120W15 ampere outlet served by a 20 ampere branch circuit. Built-In, Over the Range and Range models require a 20 ampere outlet served by a 20 ampere branch circuit. Outlets must be properly installed and grounded in accordance with applicable electric codes. If your model requires a 20 ampere outlet and you do not have one, contact an electrician or call 1-800-330-9707. For proper operation, no other appliance should be plugged into the same branch circuit as the High Speed Oven.

OVEN START-UP

When you first plug in the microwave oven to the wall outlet the display will show a colon:

1. To set the Clock: Touch Clock; Enter the current time of day by touching the correct number pads. You must set at least 3 digits (*one for hour(s) and two for minutes*). For minutes less than 10, precede the "minutes" digit by a 0. Example: for 5 minutes after 2, set 2:05. The colon will flash between hour and minute and minute digits.
2. Touch the start/stop pad to lock in the time. The colon will stop flashing and the clock has been set and will begin to keep current time.
The word "Clock" will always show on the display unless the oven is in a Cooking or Timer operation.

INTERFERENCE WARNING

Microwave ovens generate radio frequency energy during operations and if not installed properly, may cause interference to radio and television reception. You can determine if this unit is causing interference by turning it on and off while the interference is occurring. If interference occurs it may be corrected by one or more of the following measures:

- A. Relocate the TV, radio or High Speed Oven.
- B. Plug the oven into a different outlet so that it and the TV receiver are on different circuits.

If the interference persists, you may want to consult an experienced radio/television technician for additional suggestions.

WARNING

TO PROVIDE CONTINUOUS PROTECTION AGAINST ELECTRICAL SHOCK, CONNECT TO PROPERLY GROUNDED OUTLETS ONLY. IMPROPER USE OF THE GROUNDING PLUG CAN RESULT IN A RISK OF ELECTRICAL SHOCK.

DO NOT, UNDER ANY CIRCUMSTANCES, CUT OFF THE 3RD GROUNDING PRONG

OVEN FEATURES

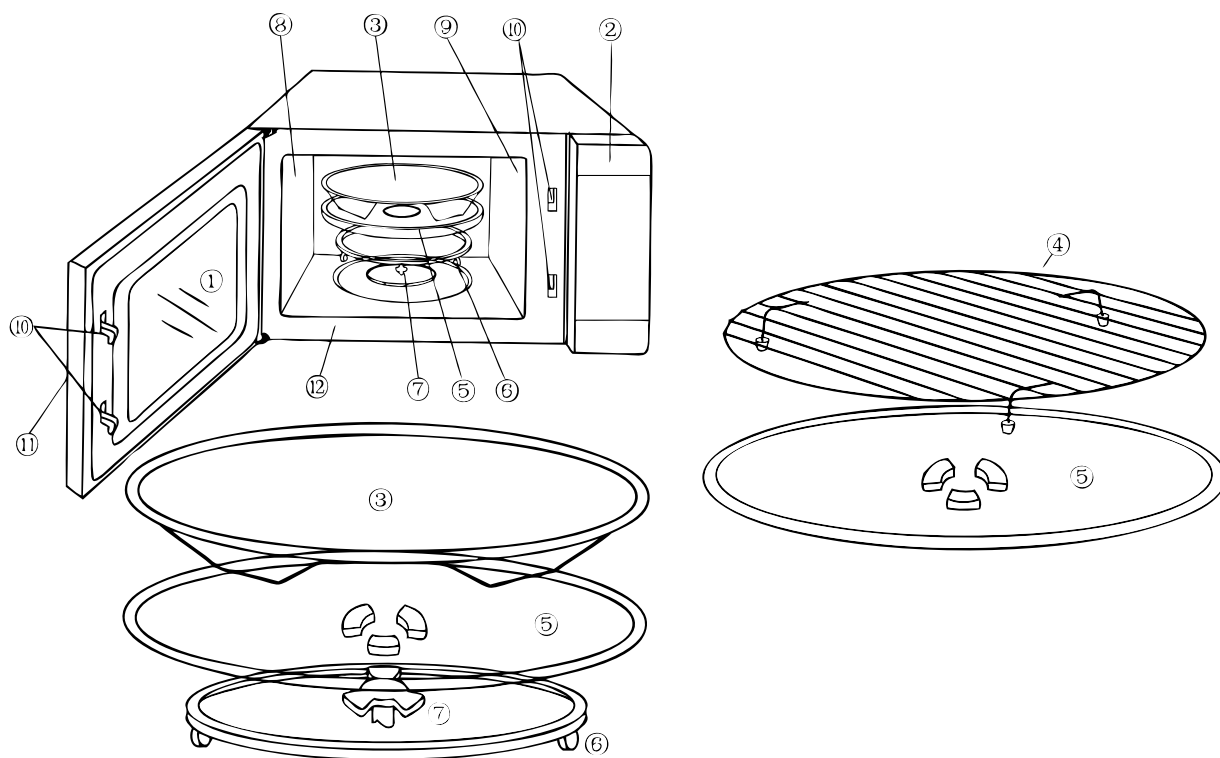

1. Window Door
2. Electronic Control Panel
3. Metal tray - Must be used for high speed, Complete Meal, Convection, Baked Potato and Cake modes. Place the metal tray on top of the glass turntable.
4. Grill Rack - Some models come equipped with a Grill Rack. Cooking instructions are included in this manual. When using this Grill Rack, place it on top of the glass turntable. **Do not** use the metal tray.
5. Rotating Glass Turntable
6. Turntable Guide Ring and Wheels
7. Turntable Driver - Must mate properly with bottom of glass turntable for proper operation.
8. Stainless steel cavity
9. Light bulb - Must be replaced by Authorized Service Agent.
10. Safety Interlock System
11. Door Handle
12. Rating plate - Serial # and model # label on the front frame of the oven.

TURNTABLE INSTALLATION

1. Remove the styrofoam packing from inside the oven. Inside the plastic with "Use and Care Manual" is a hard plastic "coupler" or driver with 3 arms. (#7) Place it on the metal shaft which is located in the center of the oven floor.
2. Inside the plastic bag with the "Use and Care Manual" is a plastic ring with wheels. (#6) Place the ring in the recessed area of the oven floor.
3. Place the glass turntable on top of the ring and make sure the turntable properly mates with the Turntable Coupler/Driver describer in Step 1. The turntable will onto turn and the oven will not cook properly unless the coupler/driver and glass tray are properly mated.
4. The glass turntable is used for all cooking modes.
5. When you use the High Speed, Complete Meal, Convection, Baked Potato or Cake modes, place the metal tray on top of the glass turntable.

Control Panel Quick Reference

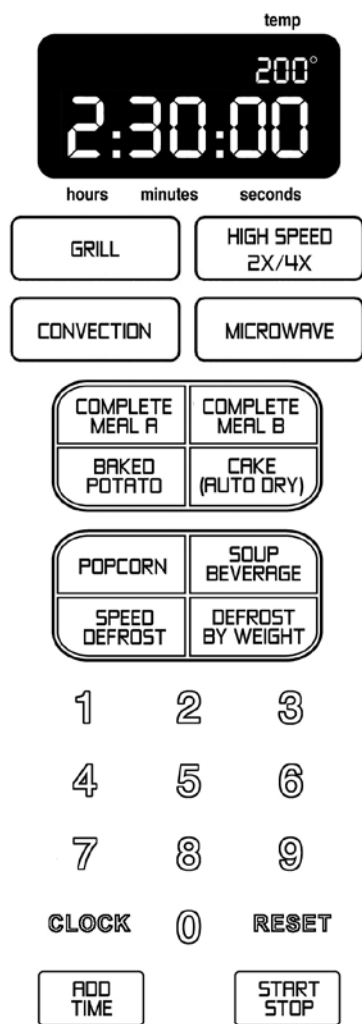

- Step 1.
Select cooking mode
Example: High Speed
- Step 2.
Enter temperature
Same as gas/electric oven
- Step 3.
Enter the normal cooking
time for a gas/electric oven
- Step 4.
Press Start

Display

Displays Clock, Cook Time and temperature with step-by-step word prompting which tells you which pad to select next for easy oven operation.

HIGH SPEED 2X or 4X PAD

Cooks and browns like a gas or electric oven in a fraction of the time. Use any cookbook or directions on any food package and simply enter the normal cooking time for a gas or electric oven. The electronic control will automatically calculate the correct High Speed cooking time and pre-heating if necessary.

GRILL PAD

This feature is found on some models. Place the Grill rack on top of the glass turntable and enter the cooking times shown on page 26 of this manual.

Do not use metal tray.

MICROWAVE PAD

Cooks with microwave energy.

COMPLETE MEAL A

Cooks meals, poultry or fish pieces or filets and potatoes or rice and vegetables all at the same time. Cooks with convection and microwave energy simultaneously. Complete meals for 1, 2, 3, or 4 servings. No need to cook items separately.

COMPLETE MEAL B

Cooks meat roasts or whole poultry roast and potatoes or rice and vegetables or casseroles all at the same time. No need to cook items separately.

BAKED POTATO

Uses Convection heat and microwave energy simultaneously. **USE METAL TRAY.** Press once for potatoes up to 7.9 oz. Press twice for potatoes larger than 7.9 oz. Select Quantity 1-4.

AUTO DRY 2X Models *(Not required on 4X Models)*

The heaters come on for 90 seconds to remove moisture from inside the oven cavity after microwave cooking, or you can remove any excess moisture with a paper towel or let it dry naturally.

CAKE 4X Models

Uses Convection heat and Microwave energy simultaneously to bake cakes and muffins. **USE METAL TRAY.**

POPCORN

Press once for bags up to 3 oz. to 3.5 oz. bags. To select different times press twice and select up to 3:30.

SOUP/BEVERAGE

Select number of cups or mugs from 1-4.

SPEED DEFROST

Divides input time into fourths and reduces the power level automatically from 60% to 40% to 30% to 20%.

DEFROST BY WEIGHT

Enter the weight of the food and the control automatically sets the proper defrosting time.

CLOCK

Touch the CLOCK pad once, enter the time and press START, to reset the clock, Press CLOCK, enter the time and press START.

RESET

To reset a cooking or timing function while programming the oven, touch the reset pad and start over. To reset while cooking function is in progress, the Start/Stop pad must be pressed first then reset pad can be pressed to reprogram the oven.

ADD TIME

This pad offers two new features: ADD TIME and MICROWAVE POWER LEVEL. Press once in order to add cooking time during a cooking operation, or after a cooking operation is completed, if you want the food cooked to a greater degree. If the pad is touched twice it can be used to set microwave power. The oven is automatically programmed or Pre-set to HIGH power. To select a LOWER power setting enter the number 0 to 9 which will result in a power setting of 0 up to 90%. For example, if you press the 1 oven will operate at 10 power, press 5 for 50% power, etc. *(See page 7 for more details).*

START/STOP

Press the pad to start or stop the oven.

High Speed, Complete Meal, Complete Meal, Convection, Baked Potato or Cake Cooking Modes

Place Grill Rack on the Glass Turntable.
Place food or regular oven safe cookware directly on the Metal Tray.

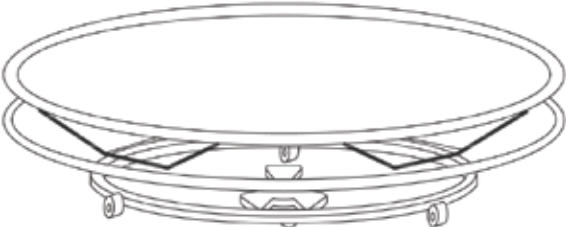

- HIGH SPEED 2X/4X
- CONVECTION
- COMPLETE MEAL A
- COMPLETE MEAL B
- BAKED POTATO
- CAKE

The metal tray must be used for High Speed, Complete Meal, Convection, Baked Potato and Cake cooking modes. NEVER use the metal tray during a microwave only function. The metal tray has a special easy to clean coating. Sharp knives and forks should never be used directly on the surface of the tray, as they could scratch the finish. To clean the tray, wash with any dish washing soap and dry with a towel.

Grill Cooking

Place Grill Rack on the Glass Turntable.

- GRILL

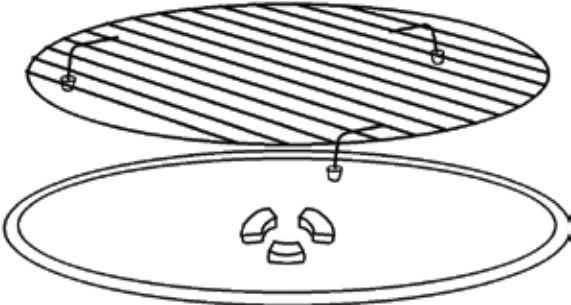

If your oven comes with a Grill Rack, or if you purchase a Grill rack from Half Time Oven, place the Grill Rack on the Glass Turntable and DO NOT use the Metal Tray.

Microwave Cooking

Place food or microwave safe cookware directly on the Glass Turntable.

- MICROWAVE

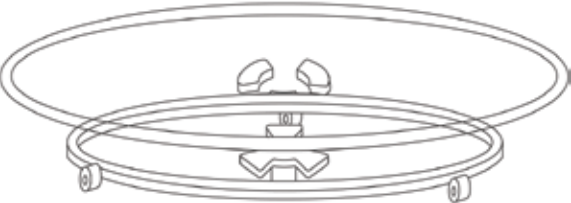

The Glass Tray included with the oven should remain in place during every cooking function. NEVER USE THE METAL TRAY DURING A MICROWAVE ONLY FUNCTION.

Additional Glass, Metal Trays, Grill Racks or Glass Cookware for Complete Meal cooking can be ordered for \$29.95 each including shipping and handling. Send check to: Half Time Oven, Inc., 7570 South Federal Highway, Suite 6, Hypoluo, Florida 33462 or call 1-800-330-9707

Setting The Clock



1. When the oven is first plugged into a wall outlet touch the **CLOCK** pad once, the display will show "ENTER TIME"
2. Enter the current time of day by touching the correct number pads. You must set at least 3 digits. (*one for hour(s) and two for minutes after 2, set 2:05*) After the correct time of day has been set press **START** to activate. The colon will become steady, the word **CLOCK** will remain in the display the updated clock time will be kept.
3. To recall the time of day while cooking, Press **CLOCK** and the current time of day will be displayed for 3 sec.
4. To reset the clock Press **CLOCK**, enter time, press **START**.

Using the Reset Pad



1. to reset the cooking or timing function while programming the oven, touch the **RESET** pad and start over. the **RESET** will clear the oven back to the current time of the day.
2. To reset while a cooking function is in progress, the **START/STOP** pad must be pressed first. Then the **RESET** pad can be pressed to reset the function.

Using the START/STOP Pad



Touch **START** as the final step in setting the oven. If you touch the **POPCORN**, **SOUP/BEVERAGE**, **BAKED POTATO** or **AUTO DRY** pads, the oven will restart automatically. If you open the door during a cooking operation, the **START** pad must be pressed to re-start the oven after you close the door.

To stop the oven open the door press the **START/STOP** pad.

Using the ADD TIME Pad



This pad also offers two features: **ADD TIME** or **MICROWAVE POWER LEVEL**.

Press once in order to **ADD TIME**

Press twice to change the **MICROWAVE POWER LEVEL**.

You can **ADD TIME** to any cooking operation: High Speed Convection, Microwave Grill, Complete Meal, Baked Potato, Cake. If you **ADD TIME** during a cooking operation without opening the door, the time will be added and the oven will continue to run. If you open the door to check the food during the operation or after cooking operation has been completed, you can still **ADD TIME**. Press the **ADD TIME** pad, enter the amount of time you want to add, then press the **START** pad. You do not have to reset the cooking mode or temperature, the electronic control will automatically remember it.

If the **ADD TIME** pad is touched twice it can be used to set **MICROWAVE** power. The oven is automatically programmed or pre-set to **HIGH** power. To select a **LOWER** power setting, enter the number 0 to 9, which will result in a power setting of 0 up to 90%. For example, if you press 1 the oven will operate at 10%, press 5 for 50%, etc.

High Speed Cooking

High Speed Cooking combines Convection heat for flavor and browning and simultaneously uses microwave energy for speed. This combination cooks like a conventional Gas or Electric Oven but in a fraction of the time.

**HIGH SPEED
2X**

**HIGH SPEED
4X**

Use any cookbook or the direction from any food package.
Step 1: Enter the same temperature as a gas or electric oven.
Step 2: Enter the normal cooking time for a gas or electric oven, then press **START**. The electronic control will automatically calculate the proper High Speed cooking time and add preheating if necessary.

Automatic Preheat

Like convectional ovens, this oven should be preheated if the cooking time is short and the oven is cold. You enter the normal cooking time for a gas or electric oven. When the **START** pad is pressed, the electronic control will automatically add the preheat time if required

If the oven from a previous cooking operation, the electronic control will add a preheat time, but after 10 seconds a sensor inside the oven will determine the oven is already hot and the preheating will automatically be removed.

THE ELECTRONIC CONTROL WILL AUTOMATICALLY ADD PREHEATING IF THE OVEN IS COLD				
PREHEATING TABLE	150°-250° F	no preheat	355°-375° F	4:00 minutes
	255°-300° F	3:00 minutes	380°-450° F	5:00 minutes
	305°-350° F	3:30 minutes		

Using the Special Metal Tray

Foods can be placed directly on the metal cooking tray provided with the oven or they can be placed in oven safe glass, ceramic or metal pans and placed on the metal tray for cooking.

The legs on the metal tray position the food to allow hot air to circulate all around the food (*top, bottom and sides*) for optimum cooking results

this tray can be placed on top of the glass tray when cooking in the **High Speed, Complete Meal, Convection, Baked Potato or Cake Modes**.

DO NOT USE this tray in the grill, Microwave, Speed Defrost, Defrost by weight, Popcorn or Beverage pad modes.

To Set High Speed Cooking

- Place food directly on the special metal tray or in a metal, glass or ceramic cooking utensil and then place the utensil on the top of the metal tray. Press the **HIGH SPEED PAD**. The word **HIGH SPEED, ENTER TEMP** will be lit in the Display. Enter desired temperature from 150° F to 450° F. If the inputted temperature is not in 5 degree increment, the oven will round the closest 5 degree increment. If an incorrect temp is entered an error beep will sound. When the 3 temp digits have been selected **ENTER TIME** will be lit in the display.
- Enter the same cooking time as a gas or electric oven. The electronic control will automatically calculate the High Speed cooking time.
- Press the **START PAD** and the oven will begin to cook. As the cooking time progresses you may hear the oven cycling. This is when the oven "thermostats" to maintain the set temperature. This function is just like your convectional gas or electric oven.
- Up to four hours can be entered. For example, to set one hour and 30 minutes you must press 1 for hours, 30 for minutes, and 00 for seconds. 1:30:00 will appear in the display.
 

Up to 99:00 minutes can be entered. For example, if you want to set 45 minutes, you can enter 45 for minutes, 00 for seconds. 45 : 00 will appear in the display

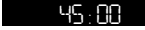

Up to 99 seconds can be entered. For example, if you want to enter 30 seconds enter 30 : 30 will appear in the display



- If you decide to add cooking tie it can be done during or after the cooking operation is completed by pressing the **ADD TIME PAD**. If you open the door and decide to **ADD TIME**, the **START PAD** must be pressed to restart the oven after the door is closed.

Complete Meal Cooking

Type A

COMPLETE MEAL A

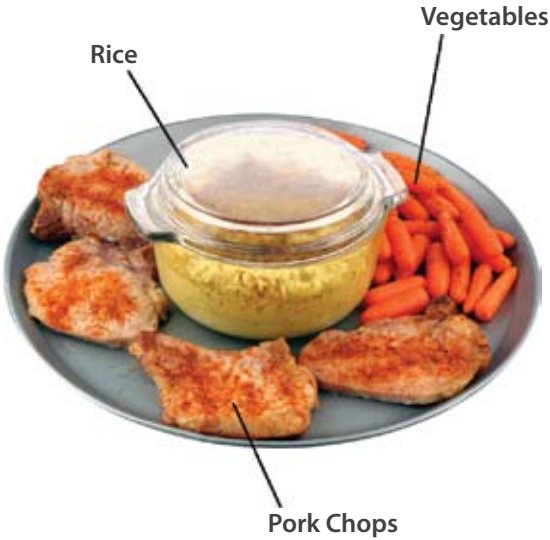
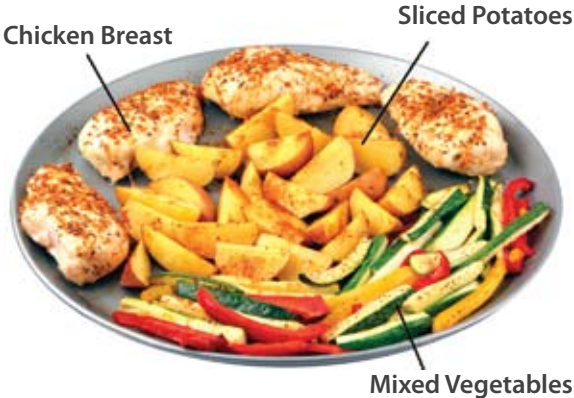
Use for meat, poultry or fish pieces/slices.



Type B

COMPLETE MEAL B

Use for meat roasts or whole poultry.

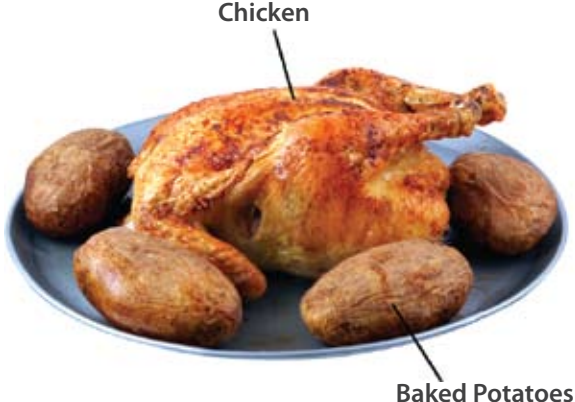
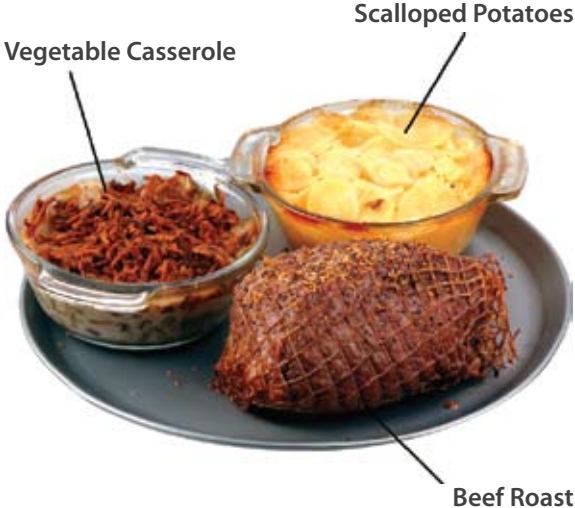

Setting Complete Meal Type A

COMPLETE
MEAL A

Complete Meal A

Cooks meat, poultry or fish pieces or filet and potatoes or rice and vegetables all at the same time. Cooks with convection and microwave energy simultaneously. Complete meals for 1, 2, 3 or 4 servings. No need to cook items separately. (See charts on page 20) Foods such as quick cooking rice or canned foods can be cooked in a small covered dish, Placed on the Meal Tray. Place dish directly on the tray with the other foods.

1. To set complete Meal Press COMPLETE MEAL A Pad. 350 degrees will show in the temp display and the words "ENTER", "QTY" will light in the display.
2. Select a quantity from 1-4, Press the START/STOP Pad.
3. The preheat time will automatically be added if required.
4. Remember to use your "Hot Pads" when removing the finished complete meals from the oven.

Setting Complete Meal Type B

COMPLETE
MEAL B

Complete Meal B

Cooks meat roasts or whole poultry and potatoes or rice and vegetables or casseroles all at the same time. No need too cook items separately. See chart on page 21.

1. Press Complete Meal B Pad.
2. Enter the cooking temperature for the meat or poultry roast. USE CHARTS & TABLE ON PAGE 22.
3. Enter the cooking time based on the weight of the meat or poultry roast. USE TABLE ON PAGE 22.
4. Press START
The Electronic Control will automatically add preheating time if required plus an additional five minutes in order to cool all the food at the same time.

Setting Convection

CONVECTION

The Convection Mode Setting cooks similar to your Gas or Electric Oven. Use the same temperature settings as you would in your gas or electric oven.

All foods must be cooked on the Special Metal Tray, which is sitting on top of the glass tray. Oven Safe Glass, Ceramic or Metal baking dishes can be placed on the Special Metal Tray or foods can be placed directly on the special metal tray.

Convection cooks with forced hot air which allows the foods to brown evenly on all sides plus some microwave energy for speed. See cooking charts on pages 23-26.

1. To use Press the CONVECTION pad. The "Time Display" will blank. The words "Enter", "Temp" will be lit in the display. Enter the temperature from 150 F to 450 F. When 3 digits have been entered the words "Enter", "Time" will be lit in the display.
2. Enter cooking time. You can set times up to 1 hour and 30 minutes or you can enter up to 99 minutes and 99 seconds. For example, to enter 1 hour and 20 minutes, press 1 for hour, 20 for minutes and 00 for seconds.

1:20:00

Press Start. "CONV" will remain lit in the display and the oven will stat to cook.

3. The Convection cooking time for most food items is 50% less than a gas or electric oven. For proper cooking times see the cooking charts on pages 23-26.

Setting Microwave Cook and Power

MICROWAVE

1. To cook at "Hi" Power simply set cook time by touching number pads. For example to set 3 minutes, touch 3-0-0 and START. You do not have to touch MICROWAVE pad before setting time.
2. Enter the cooking time. You can set times up to 99 minutes and 99 seconds. For example, if you want to set 20 minutes, enter 20 for minutes and 00 for seconds. 20:00 will appear in the display.

20:00

1. After setting Microwave time, press the ADD TIME pad twice, then enter a single digit representing the power level desired, touch START.

USE THESE SINGLE DIGITS TO SET POWER LEVELS

Digit	% of Power	
9	90	
8	80	
7	70	Med Hi
6	60	
5	50	Med
4	40	
3	30	Lo
2	20	
1	10	Warm

If you are cooking at a lower power level and wish to return to HI power press the ADD TIME pad three times.

Stage Cooking

As you become more familiar with your new oven you may want to experiment by combining cooking functions. For example, to defrost an item and then cook it at high speed, follow these steps

1. Press the SPEED DEFROST pad. The words "DEF MICRO" will show in the display with the words "ENTER TIME". Select the desired time for defrosting.
2. Next press the HIGH SPEED pad. The words "HIGH SPEED" and "MEM" (memory) will show in the display with the words "ENTER TIME" will appear in the display. Enter the time.
3. Press START. The time will begin counting down, first in the SPEED DEFROST mode and then in the HIGH SPEED mode. At the completion of the SPEED DEFROST mode the words "MEM" and "DEF MICRO" will disappear from the display. The words "HIGH SPEED" will appear and the oven will start in cooking in the HIGH SPEED mode.

Two-Stage Cooking

Two-stage MICROWAVE function lets you cook a food at two different power levels with one-time settings. Some recipes and package directions use two cooking steps.

SET STAGE 1

Assuming "Hi" Power, just touch number pads for easy set time. (Most 2-stage recipes start with "Hi", but you can also switch power levels after setting cook time)

DO NOT TOUCH START until you have completed Stage 2 setting.

For example, rice should be cooked in two stages. Stage 1 starts rice at HIGH for 5 min. Stage 2 completes cooking 10-12 minutes at "5".

SET STAGE 2

Touch MICROWAVE pad then enter proper cooking time. Press ADD TIME pad twice and enter the lower power level designed for second stage. MEM will show in the display. Touch START. As cooking is complete in the first stage the control will sound a single beep. the word MEM will disappear from the display and the second stage Microwave time will appear in the display.

Setting Speed Defrost

Speed Defrost automatically sets microwave power for quick thawing of small to medium size foods. Use the defrost chart in this manual to enter the defrost time. Some foods benefit from being turned over, rearranged or broken apart if separate pieces are frozen together. For larger frozen items use Defrost By Weight.

To Set SPEED DEFROST

1. Touch SPEED DEFROST. Display will prompt to enter "Time".
2. Enter desired Speed Defrost time by touching correct number pads.
3. Touch START, DEF shows in the display and time begins counting down. After time has elapsed the control will sound multiple beeps and END will appear in the display.

SPEED
DEFROST

"How do I know whether to set Speed Defrost or Defrost by Weight?"

This is determined by the type of food being defrosted and the amount of attention that must be paid to the food. The automatically-coded Defrost by Weight program is specifically designed for large, dense meat roasts which must thaw slowly for even defrosting. Defrost by Weight requires only one turn-over of the meat.

Instant Action Pads

BAKED
POTATO

Baked Potato

The **METAL TRAY MUST BE USED** place on top of glass tray. Uses microwave energy and convection heat simultaneously. To set:

1. Press BAKED POTATO pad once for potatoes weighing less than 7.9oz. The display will show a red "1". Press the BAKED POTATO pad twice for potatoes weighing more than 7.9oz. The display will show a red "2"
2. The words "ENTER", "QTY" will appear in the time display. Select a quantity from 1 to 4. These numbers will appear in the time display. Once the quantity is selected the control will start the oven after 3 seconds. If no quantity is selected the control will assume a quantity of 1 and start counting down after 3 sec. The control will sound multiple beeps at the end of the cycle and the word "END" will appear in the display.

SOUP/
BEVERAGE

BEVERAGE or SOUP

This pad uses Microwave energy only. Up to 4 large cups or mugs or beverage (coffee, tea, cocoa, cider, etc.) can be heated at once.

Press BEVERAGE and the words "ENTER", "QTY" will be lit in the display. Select 1-4 using the number pads. If no quantity has been selected after 3 seconds the control will assume a quantity of one and start counting down.

POPCORN

Popcorn

This pad uses microwave energy only. Popcorn is a favorite snack. POPCORN control automatically sets the correct time for a 3-3.5 oz. bag of Microwave popcorn. Place popcorn on glass turn tray and press POPCORN pad.

YOU CAN CHANGE THE POPCORN SETTING TO "REMEMBER" A DIFFERENT COOK TIME for your favorite brand or size of POPCORN. Press POPCORN twice. "ENTER", "TIME" appears in the display. Enter your desired time up to 3:30. When you press START the control will start counting down the new time and remember it. Next time, just press POPCORN twice to get the new setting. If you want to reset it again repeat the above steps.

NOTE: On oven models mounted under a cook top, after you touch one of the instant action pads, the START pad must be pressed to start the oven.

Defrost By Weight

DEFROST BY WEIGHT

Set DEFROST BY WEIGHT for any weight up to 6 pounds. Because it is more gentle defrost setting the "SPEED DEFROST", it is especially good for meats which are dense in the center but vulnerable to overcooking of the edges.

1. Check weight of meat. If the weight is more than 6 pounds, use the SPEED DEFROST feature on page 13

Unwrap meat before defrosting.

Touch DEFROST BY WEIGHT pad. ENTER lbs (*pounds*) or oz. (*ounces*). For example, to defrost an item that weighs 1lb 6oz, enter "106". Numbers to the left of the colon represent pounds, numbers to the right of the colon represent ounces.

You must enter three digits. For example, you must enter "300" for an item that weighs 3 pounds.

2. Press START. The timer will start counting down and lbs and oz. will disappear from the display. The word DEF will remain lit.

3. Part way through the defrosting the oven will sound two long beeps and pause. At this point you must open the door and turn over or rearrange the food to insure complete defrosting. After closing the door press START again the program and countdown will resume.
4. At the end of the cycle the control will sound 4 long beeps and the word END will appear in the display. When the door is open the display will go back to the current time of day.

Special Tips for Defrost by Weight

Allow enough time for defrosting because it is slower than SPEED DEFROSTING. With DEFROST by WEIGHT, low power microwaving is interspersed with "resting" or "standing" periods. Where no microwaves enter the oven. These no-microwave periods allow meat to equalize in temperature before the next period of defrosting automatically comes on.

With DEFROST BY WEIGHT there's no need to guess how long to defrost. DEFROST BY WEIGHT automatically sets the correct thawing time, but you must enter the food weight accurately.

Automatic DEFROST BY WEIGHT times are based on meat that is solidly frozen at 0 degrees F. If meat has been partially defrosted remove from oven before the total time has elapsed.

Place meat on microwave-safe rack or in microwave roasting dish on the rotating glass tray for best results. Place meats fat-side down and poultry breast-side-down.

Care and Maintenance

CLEANING

IMPORTANT: ALWAYS UNPLUG OVEN AND BE SURE OVEN IS COOL BEFORE CLEANING.

To maintain the appearance of your oven, never use abrasive cleaning agents (such as cleansing powders, scouring pads or steel wool pads) Also, never use commercial oven cleaners on any part of your High Speed Oven.

Easy Off Oven Cleaner CAN BE USED.

Some liquid cleaners can remove the shiny surface on plastic or vinyl. Therefore, never spray or pour liquid cleaners onto a surface. Spray or pour cleaner onto a cloth or sponge and then clean.

Clean up splatters or spills in your stainless steel cavity as quickly as possible. Once the spills have baked on they are harder to get off. Use any goof dish detergent with a soft cloth or sponge. For hard to clean soiled areas, oven cleaners such as "Easy Off" can be used. Be careful not to spray these cleaners into any of the holes punched in the cavity back or side walls. Do not spray on or in the light bulb area, The spray can cause the light bulb to fail. All the oven cavity holes can be covered with masking tape before using the oven cleaner spray.

Service

BEFORE CALLING SERVICE, CHECK THE FOLLOWING

- Oven does not operate.
 - Is power cord plugged into wall outlet?
 - Is house fuse blown or circuit breaker tripped?
 - Is oven correctly programmed?
 - Is oven door closed?
 - Was START-STOP pad pressed once to turn oven on?
- Food is under cooked.
 - Was the metal tray used in the high speed? Complete Meal, Convection, Baked Potato and Cake setting and placed on top of the glass turntable?
 - If the grill rack was used, was it placed on top of the glass turntable?
 - Was the amount of food more than called for in the recipe?
 - Was the cooking time too short for the amount of food?
 - Was the set oven temperature too low, or if in Microwave was the power level too low?
 - Was the household voltage too low?
 - Is there another appliance on the same circuit as the food being cooked?
 - Was the food placed in a dish that was too small for the amount of food being cooked?
 - Was the food completely defrosted before cooking?
- Food is overcooked.
 - Was the amount of food less than called for in the recipe?
 - Was the cooking time too long for the amount of food?
 - Was the oven temperature or microwave power level too high?
 - Was the food placed in a dish that was too large for the amount of food being cooked?
 - Was the initial temperature of the food higher than normal?
- Oven light does not turn on.
 - Is power cord plugged into wall outlet?
 - Is house fuse blown or circuit breaker tripped?
- House fuse or circuit breaker trips when the oven is turned on.
 - Counter top models must be plugged into a separate 120V, 15 ampere outlet served by a 20 ampere branch circuit. Built-In, Over the Range and Range models require a 20 ampere outlet served by a 20 ampere branch circuit. For proper operation, no other appliances should be plugged into the same branch circuit as the High Speed Oven.

OUTSIDE SURFACES

WRAPPER

Clean the outside of the oven with a glass or all surface cleaner. Be careful when cleaning around louvers. Rinse and Dry.

To clean the viewing window use a liquid or glass cleaning agent and a sponge or soft cloth. To prevent scratching the plastic surface do not use paper toweling.

POWER CORD

Be sure oven is unplugged. Wipe cord with a damp sudsy cloth, rinse and dry thoroughly before plugging cord back into outlet.

LIGHT BULB

This bulb is to be replaced by properly qualified service personnel.

6. Oven comes without pressing **START**?
 - Did you press one of the **INSTANT START** Keys? **Baked Potato, Soup/Beverage, or Popcorn**? If one of these keys has been pressed the oven will
 - Automatically start cooking in 3 seconds without pressing **START**.

7. Oven feels hot to touch.
 - This is High Speed Oven gets hot on the outside just like your gas or electric range. The door and outer cabinet will feel hot when you have been cooking in the **High Speed, Complete Meal, Convection, Grill, Baked Potato, Cake Mode**. Be sure to use **HOT PADS** while handling foods and dishes in the oven.

8. I can see light through the cracks in the oven.
 - The light is located outside of the oven cavity. There may be places you can see the light, but all microwave energy is contained in the cooking cavity.

9. Accumulation of moisture on the inside of the door.
 - This oven is designed to cook efficiently with heat and therefore is extremely well insulated and sealed. This causes moisture to form inside the cavity. In the **High Speed and Convection** modes, the moisture is evaporated by the heaters. In the microwave mode, the heaters are not on so, moisture may accumulate. Simply wipe it off at the end of cooking cycle with a soft rag or paper towel or press the **AUTO DRY** pad.

10. High Speed Cooking is too long/short.
 - The **High Speed, Complete Meal and Convection** cooking modes operate like a gas or electric oven. Check the food and adjust the cooking time to suit your taste as you do when cooking in a regular oven.
 - Press the **ADD TIME** pad and enter added cooking time if you want to cook the food longer.

11. My light bulb is out, how can I replace it?
 - The light bulb can be replaced **ONLY** by a qualified service agent.

12. Looks like the upper left hand corner or my door is chipped or broken.
 - The upper left hand corner of the door has been notched out for clearance of the door hinge. This is normal.

13. Do I have to save the box and the packing material that came with the oven?
 - if you ever have to return the oven for any reason it is important to package it properly including the glass and metal tray. If you do not want to save the carton and packaging material and you need to return the oven, take it to a packing service, such as UPS to be properly repackaged.

14. How do I clean my oven?
 - Please see the **Care and Maintenance** section on page 15 of this manual. Glass or all surface cleaners may be used. *“Easy Off”* oven cleaner may be used to clean heavily soiled areas. Do not use abrasive cleaning agents, scouring pads or steel wool pads.

HOW TO OBTAIN SERVICE

Do not attempt to service the appliance yourself unless directed to do so in this book. Call 1-800-330-9707 to get the name and phone no, or your nearest service agent.

If you are not satisfied with the response to your service request, write to:
Half Time Oven, P.O. Box 6006, West Palm beach, FL 33405.

Include the complete model and serial number of appliance, the name and address of the dealer from which you purchases the appliance, the date of purchase and details concerning the problem.

HIGH SPEED COOKING GUIDE

1. ALL FOOD MUST BE COOKED ON THE METAL TRAY PACKED INSIDE THE OVEN
2. Place the metal tray on the glass turntable.
3. Metal tray acts like an oven rack and allows hot air to circulate under the food.
4. Food can be cooked directly on the metal tray or place the food in a metal, glass or ceramic cooking utensil and then place the utensil on the top of the metal tray.
5. USE HOT PADS WHEN HANDLING METAL TRAY OR UTENSILS AFTER COOKING
6. If desired, an oven safe meat thermometer can be used for poultry and meats.
7. Adjust the cooking time for personal tastes by using the ADD TIME pad.
8. Enter the cooking time for a regular gas or electric oven shown in any cookbook or on any food package, or you can use the cooking times shown in this manual. After you enter the cooking time for a gas or electric oven, the electronic control will automatically calculate the proper High Speed cooking time and add preheating time if required.

Food	Dish	Oven Temp.	Comments	
Baking Breads	Biscuits	Metal pan	450°	
	Corn Bread	8 x 8 pan	400°	
	Muffins	Muffin pan	400°	
	Popovers	Custard cups	450° then 350°	<i>Pierce each Popover with a tooth pick after removing from oven to allow steam to escape</i>
	Nut Bread or Fruit Bread	Loaf pan	350°	<i>Interiors will be moist and tender</i>
	Yeast Bread	Loaf pan	375°	
	Plain or Sweet Rolls	Metal pan	350°	<i>Lightly grease baking sheet</i>
Cakes	Angel Food	Tube pan	350°	<i>Invert and cool in pan</i>
	Cheese Cake		350°	<i>After cooking turn oven off and let cheesecake stand in oven 30 min. with door ajar</i>
	Cup Cakes		350°	
	Fruit Cake (<i>Loaf</i>)		350°	<i>Interior will be moist and tender</i>
	Gingerbread		350°	
	Yellow Cakes, Cake Mixes	8" pan	350°	
	Bunt Cake	Metal pan	350°	<i>Grease and flour pan</i>
	Pound Cake	Loaf pan	350°	<i>Cool in pan 10 min. before inverting on wire rack</i>
Cookies	Bar	8 x 8	350°	<i>Use same time for bar cookies from a mix</i>
	Drop or Sliced	Metal tray	350°	<i>Use same time for solid cookies from a mix</i>



HIGH SPEED COOKING GUIDE

Food	Dish	Oven Temp.	Comments	
Convenience Foods	Frozen Bread Dough	Loaf Pan	350°	
	Pizza Self Rising Crust Pizza	Metal Tray	400° 425°	Follow package directions, place on metal tray Follow package directions, place on metal tray
	Slice & Bake Cookies	Metal Tray	375°	Let stand a few minutes before removing from tray
Fruits & other Desserts	Baked Apples or Pears		350°	Bake in utensil with shallow sides
	Bread Pudding		300°	Pudding is done when knife inserted near center comes out clean
	Cream Puffs		400°	Puncture puffs twice with toothpicks to release steam after 15 min. of baking time
	Custard (individual)		350°	Set cups in baking dish. Pour boiling water around cups to a depth of 1 in.
	Meringue shells		350°	When done, turn oven off and let shells stand in oven 1 hour to dry
Pies & Pastries	Frozen		375°	Follow procedures on package.
	Meringue-Topped		325°	
	Two Crust		400°	
	Quiche	Pie Plate	350°	Let stand 5 min. before serving
	Pastry Shell		400°	Pierce pastry with fork to prevent shrinkage
Casseroles	Meal, Chicken, Seafood Combinations		350°	Cook times vary with casserole sizes and ingredients
	Pasta		350°	Cook times vary with casserole sizes and ingredients
	Potatoes, Scalloped		350°	Let stand 5 min. before serving
	Vegetable		350°	Cook times vary with casserole size and ingredients
Main Dishes	Meat Loaf	Loaf Pan	350°	
	Beef & Bean Casserole		375°	
	Stuffed Peppers		350°	Use green, red or yellow peppers



Meats	Dish	Dish	Time/Min	Oven Temp.	Temperature	Standing Time	
Beef	Rib Roasts Bone-In	Metal Tray	18 to 20	325°	60° Med. Rare	10 to 15 Minutes	
			20 to 22	325°	70° Med.	10 to 15 Minutes	
			22 to 26	325°	75° Well	10 to 15 Minutes	
	Boneless Rib, Top Sirloin	Metal Tray	23 to 26	325°	60° Med. Rare	10 to 15 Minutes	
			27 to 32	325°	70° Med.	10 to 15 Minutes	
			32 to 39	325°	75° Well	10 to 15 Minutes	
	Sirloin Tip/Rump/Round	Metal Tray	30 to 35	325°	60° Med. Rare	10 to 15 Minutes	
			35 to 40	325°	70° Med.	10 to 15 Minutes	
	Tenderloin, Whole	Metal Tray	17 to 21	325°	60° Med. Rare	5 to 10 Minutes	
			23 to 24	325°	70° Med.	5 to 10 Minutes	
	Ham, Fully Cooked	Boneless	Metal Tray	34 to 42	325°	70°	10 to 15 Minutes
		Bone-In	Metal Tray	28 to 40	325°	70°	10 to 15 Minutes
Lamb	Bone-In	Metal Tray	14 to 20	325°	60° Med. Rare	10 to 15 Minutes	
			20 to 26	325°	70° Med.	10 to 15 Minutes	
			26 to 30	325°	75° Well	10 to 15 Minutes	
	Boneless	Metal Tray	24 to 30	325°	60° Med. Rare	10 to 15 Minutes	
			30 to 34	325°	70° Med.	10 to 15 Minutes	
			36 to 40	325°	75° Well	10 to 15 Minutes	
Pork	Bone-In	Metal Tray	20 to 26	325°	70° Med.	10 to 15 Minutes	
	Boneless	Metal Tray	26 to 32	325°	70° Med. Well	10 to 15 Minutes	
			34 to 40	165°	75° Well	10 to 15 Minutes	
	Pork Chops Qty 4	Metal Tray	40 to 44	325°	80° Well		
Poultry	Whole Chicken	Metal Tray	20 to 24	350°	85°	10 to 12 Minutes	
	Chicken Pieces, 2-2.5 lb.	Metal Tray	35 to 40 <i>(Total Time)</i>	350°	85°		
	Cornish Hens, Unstuffed	Metal Tray	1 hour <i>(Total Time)</i>	350°	85°		
	Duckling	Metal Tray	20 to 24	350°	85°		
	Turkey Breast	Metal Tray	20 to 24	325°	85°		
Seafood	Fish Filets or Steaks	Metal Tray	20 to 24	400°			
	Lobster Tails		20 to 26	350°			
	Shrimps 1-2 lb.		14 to 20				
Vegetables	Acorn Squash Halves		1 hour	375°	<i>Pierce skin in several places, Add 1/4 C water</i>		
	Baked Potatoes	Metal Tray	1 hour	425°	<i>Turn squash cut side up after 30 min. and cover.</i>		
	Twice backed Potatoes	Metal Tray	25 to 30	400°	<i>Pierce skins with fork before baking</i>		

COMPLETE MEAL COOKING GUIDE TYPE B

1. ALL FOODS MUST BE COOKED ON THE METAL TRAY PACKED INSIDE THE OVEN
2. Place the metal tray on the glass turntable.
3. Metal tray acts like an oven rack and allows hot air to circulate under the food.
4. Food can be cooked directly on the metal tray, or place food in a glass, ceramic or metal pan.
5. Meat, roast or whole poultry can be placed on one side of the metal tray and glass bowls for the vegetables and starch food items can be placed on the other side of the tray. If necessary special cooking bowls from Half Time Oven, Inc. can be stacked on top of each other in order to accommodate all the food items. SEE EXAMPLES BELOW.
6. Cook Meat, Potatoes, Vegetables and Casseroles at the same time, all food will cook properly in the same amount of time. No need to cook items separately.

To cook a Complete Meal Type B:

Press Complete Meal B Pad

Enter the cooking temperature for the meat or poultry roast. USE TABLE ON PAGE 22.

Enter the cooking time based on the weight of the meat or poultry roast. Use the times from any cookbook or the directions from any food package, or use the table on page 22. All these cooking times are for regular gas or electric ovens. The electronic control will automatically calculate the proper High Speed cooking time.

Press START

The Electronic Control will automatically add preheating as required plus five minutes in order to properly cook all of the food at the same time.

Select an item from each category in appropriate portions

Main Entree

Beef Roast
Ham
Lamb Roast
Pork Roast
Whole Chicken
Duck
Turkey Breast
Meat Loaf

Vegetables

Fresh Vegetables (*place on the metal tray*)
Frozen Vegetables (*place in a separate bowl*)
Green Bean or Vegetable Casserole (*place in a separate bowl*)

Starch

Baked Potatoes 3-4
Rice Casserole (*place in a separate bowl & cover with a glass lid*)
Baked Beans (*place in a separate bowl & cover with a glass lid*)
Scalloped Potatoes (*place in a separate bowl*)

Dishes for Rice, Vegetables or Casseroles can be stacked to make room for a Roast and Baked Potatoes



PLACE ALL FOODS DIRECTLY ON THE METAL TRAY

Order glass cooking utensils by calling 1-800-330-9707

Complete Meal Type B Main Entree

Meats		Dish	Time/Min	Oven Temp.	Temperature	Standing Time	
Beef	Rib Roasts Bone-In	Metal Tray	18 to 20	325°	140° Med. Rare	10 to 15 Minutes	
			20 to 22	325°	155° Med.	10 to 15 Minutes	
			22 to 26	325°	160° Well	10 to 15 Minutes	
	Boneless Rib, Top Sirloin	Metal Tray	23 to 26	325°	140° Med. Rare	10 to 15 Minutes	
			27 to 32	325°	155° Med.	10 to 15 Minutes	
			32 to 39	325°	160° Well	10 to 15 Minutes	
	Sirloin Tip/Rump/Round	Metal Tray	30 to 35	325°	140° Med. Rare	10 to 15 Minutes	
			35 to 40	325°	155° Med.	10 to 15 Minutes	
	Tenderloin, Whole	Metal Tray	17 to 21	325°	140° Med. Rare	5 to 10 Minutes	
			23 to 24	325°	155° Med.	5 to 10 Minutes	
	Ham, Fully Cooked	Boneless	Metal Tray	34 to 42	325°	155°	10 to 15 Minutes
		Bone-In	Metal Tray	28 to 40	325°	155°	10 to 15 Minutes
Lamb	Bone-In	Metal Tray	14 to 20	325°	140° Med. Rare	10 to 15 Minutes	
			20 to 26	325°	155° Med.	10 to 15 Minutes	
			26 to 30	325°	160° Well	10 to 15 Minutes	
	Boneless	Metal Tray	24 to 30	325°	140° Med. Rare	10 to 15 Minutes	
			30 to 34	325°	155° Med.	10 to 15 Minutes	
			36 to 40	325°	160° Well	10 to 15 Minutes	
Pork	Bone-In	Metal Tray	20 to 26	325°	155° Med.	10 to 15 Minutes	
	Boneless	Metal Tray	26 to 32	325°	155° Med. Well	10 to 15 Minutes	
			34 to 40	325°	160° Well	10 to 15 Minutes	
Poultry	Whole Chicken	Metal Tray	20 to 24	350°	180°		
	Cornish Hens, Unstuffed	Metal Tray	1 hour (Total Time)	350°	180°		
	Duckling	Metal Tray	20 to 24	350°	180°		
	Turkey Breast	Metal Tray	20 to 24	325°	180°		
Meatloaf	Beef	Loaf Pan	1 hour	350°			

COMPLETE MEAL COOKING GUIDE TYPE A

1. ALL FOODS MUST BE COOKED ON THE METAL TRAY PACKED INSIDE THE OVEN
2. Place the metal tray on the glass turntable.
3. Metal tray acts like an oven rack and allows hot air to circulate under the food.
4. Food can be cooked directly on the metal tray, or place food in a glass, ceramic or metal pan.
5. Cook Meal, Potatoes and Vegetables at the same time, all food will cook properly in the same amount of time.
No need to cook items separately.

To cook a Complete Meal Type A:

Press Complete Meal A Pad
 Enter the number of Servings 1,2,3, or 4.
 Press START
 The Electronic Control will automatically set the cooking times and temperatures as shown below.

Cooking Times and Temperatures			
	2X models	4X models	
1 serving	18 minutes	13 minutes	350°
2 servings	23 minutes	14 minutes	350°
3 servings	25 minutes	15 minutes	350°
4 servings	30 minutes	16 minutes	350°

Select an item from each category in appropriate portions

Main Entree

Chicken Breasts - pieces
 Fish Filets or Steaks
 Pork Chops
 Pork Tenderloin
 Ham Steak
 Chopped Sirloin Patty
 Turkey Tenderloin
 Chopped Meat Patties

Vegetables

Fresh Cauliflower, Broccoli, Carrots, Squash, Red, Green or Yellow Peppers
 Frozen Corn on the Cob
 Canned Corn Peas, Beans,
(place on the tray in a separate dish, cover with a glass lid)
 Frozen Vegetables - mixed,
(place on the tray in a separate dish, cover with a glass lid)

Starch

New Red Potatoes - quartered
 Frozen Twice Baked Potato
 Frozen Tatter Tots
 Frozen Corn on the Cob
 Rice *(Place in a separate bowl and cover with a glass lid)*
 Minute Rice - follow package directions. *(Other types of rice reduce water by 25%).*
 Baked beans *(cover with a glass lid)*

PLACE ALL FOODS DIRECTLY ON THE METAL TRAY

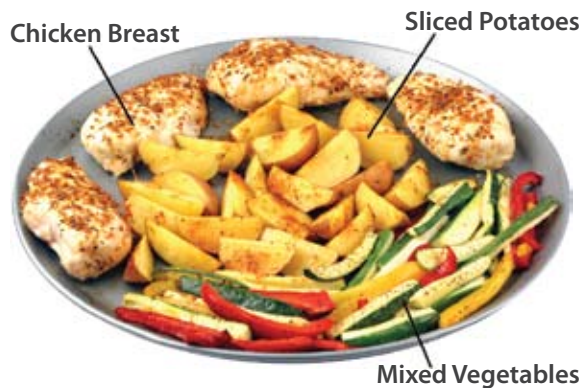

Order glass cooking utensils by calling 1-800-330-9707

CONVECTION COOKING GUIDE

1. ALL FOODS MUST BE COOKED ON THE METAL TRAY PACKED INSIDE THE OVEN
2. Place the metal tray on the glass turntable.
3. Metal tray acts like an oven rack and allows hot air to circulate under the food.
4. Food can be cooked directly on the metal tray, or place food in a glass, ceramic or metal pan.
5. USE HOT PADS WHEN HANDLING METAL TRAY OR UTENSILS AFTER COOKING
6. If desired, an oven safe meat thermometer can be used for poultry and meats.
7. This cooking mode uses turbo powered convection heat plus some Microwave Energy for speed.
(Use the cooking times shown below)
8. Adjust the cooking time for personal tastes by using the ADD TIME pad.

Food	Dish	Dish	Time/Min	Oven Temp.	Comments
Baking Breads	Biscuits	Metal Pan	9 to 10	375°	
	Corn Bread	8x9 Pan	12 to 15	400°	
	Muffins	Muffin Pan/6	12 to 15	400°	Remove from pans immediately and cool slightly on wire rack
	Popovers	Custard Cups	20 to 25 15 to 20	450° then 350°	Pierce each popover with a toothpick after removing from oven to allow steam to escape.
	Nut Bread or Fruit Bread	Loaf Pan	27 to 30	350°	Interiors will be moist and tender
	Yeast Bread	Loaf Pan	27 to 30	375°	
	Plain or Sweet Rolls	Metal Pan	9 to 11	350°	Lightly grease baking pan
Cakes	Angel Food	Tube Pan	22	350°	Invert and cool in pan
	Cheesecake		30	350°	After cooking turn oven off and let cheesecake stand in oven 30 min. with the door ajar.
	Coffee Cake		15 to 18	350°	
	Cup Cakes		10 to 13	350°	
	Fruit Cake (loaf)		45	350°	Interior will be moist and tender
	Gingerbread		20 to 23	350°	
	Yellow cakes & Cake Mixes	8" Pan	18 to 23	350°	
	Fluted Tube, Bunt Cake	Metal Pan	25	350°	Grease and Flour Pan
	Pound Cake	Loaf Pan	25	350°	Cool in pan 10 min. before inverting on wire rack
Cookies	Bar		20 to 25	350°	Use same time for bar cookies from a mix
	Drop or Sliced	Metal Tray	7 to 11	375°	Use same time for sliced cookies from a mix

Food	Dish		Time/Min	Oven Temp.	Comments
Fruits & other Desserts	Baked Apples or Pears		18 to 23	350°	<i>Bake in utensil with shallow sides</i>
	Bread Pudding		20	300°	<i>Pudding is done when knife inserted near center comes out clean</i>
	Cream Puffs		20 to 25	400°	<i>Puncture puffs twice with toothpicks to release steam after 15 min. of baking time</i>
	Custard (<i>Individual</i>)		25	350°	<i>Set cups in baking dish. Pour boiling water around cups to a depth of 1 in.</i>
	Meringue Shells		18 to 20	300°	<i>When done turn oven off and let shells stand in oven 1 hour to dry</i>
Pies and Pastries	Frozen		30	375°	<i>Follow procedures on package</i>
	Meringue-Topped		9 to 11	325°	
	Two-Crust		30	400°	
	Quiche		18	350°	<i>Let stand 5 min. before serving</i>
	Pastry Shell		10 to 13	400°	<i>Pierce pastry with fork to prevent shrinkage</i>
Casseroles	Meat, Chicken, Seafood combinations		13 to 23	350°	<i>Cook times vary with casserole size ingredients</i>
	Pasta		15 to 25	350°	<i>Cook times vary with casserole size ingredients</i>
	Potatoes - scalloped		30	350°	<i>Let stand 5 minutes before serving</i>
	Vegetable		15 to 20	350°	<i>Cook times vary with casserole size ingredients</i>
Main Dishes	Meat Loaf	Loaf Pan	30	350°	
	Beef & Bean Casserole		25	350°	
	Stuffed Peppers		15 to 18	350°	<i>Use green, red or yellow peppers</i>
Convenience Foods	Frozen Bread Dough	Loaf Pan	16 to 20	350°	
	Pizza, Self Rising Crust, Pizza	Metal Tray	17 to 20	400°	<i>Follow package-directions</i>
		Metal Tray	13 to 19	425°	<i>Follow package-directions</i>
	Sliced & Baked Cookies		10 to 12	375°	<i>Let stand a few minutes before removing from pan to cool</i>
Vegetables	Atom Squash Halves		30	350°	<i>Pierce skin in several places. Add 1/4 C water Turn squash halves cut side up after 30 min., Cover.</i>
	Baked Potatoes		30	425°	<i>Pierce skin with a fork before baking</i>
	Twice-Baked Potatoes		18 to 20	400°	

Meats	Dish	Dish	Time/Min	Oven Temp.	Temperature	Standing Time
Beef	Rib Roasts Bone-in	Metal Tray	10	325°	140° Med. Rare	10 to 15 Minutes
			11	325°	155° Med.	10 to 15 Minutes
			13	325°	160° Well	10 to 15 Minutes
	Boneless Rib, Top Sirloin	Metal Tray	13	325°	140° Med. Rare	10 to 15 Minutes
			16	325°	155° Med.	10 to 15 Minutes
			18	325°	160° Well	10 to 15 Minutes
	Sirloin Tip	Metal Tray	17	325°	140° Med. Rare	10 to 15 Minutes
			20	325°	155° Med.	10 to 15 Minutes
	Tenderloin, Whole	Metal Tray	10	325°	155°	5 to 10 Minutes
12			325°	155°	5 to 10 Minutes	
Ham, Fully Cooked	Boneless Bone-in	Metal Tray	22	325°	155°	10 to 15 Minutes
		Metal Tray	20	325°	155°	10 to 15 Minutes
Lamb	Bone-in	Metal Tray	10	325°	140° Med. Rare	10 to 15 Minutes
			13	325°	155° Med.	10 to 15 Minutes
			15	325°	160° Well	10 to 15 Minutes
	Boneless	Metal Tray	15	325°	140° Med. Rare	10 to 15 Minutes
			17	325°	155° Med.	10 to 15 Minutes
			20	325°	160° Well	10 to 15 Minutes
Pork	Boneless Bone-in	Metal Tray	13	325°	155° Med.	10 to 15 Minutes
			16	325°	155° Med. Well	10 to 15 Minutes
			20	325°	160° Well	10 to 15 Minutes
	Pork Chops - 4 Pieces	Metal Tray	22	325°	170° Well	
				(Total Time)		
Poultry	Whole Chicken	Metal Tray	10	350°	180°	10 to 12 Minutes
	Chicken Pieces 2 ½ lbs	Metal Tray	20	375°	180°	10 to 12 Minutes
				(Total Time)		
	Cornish Hens, Unstuffed		35	375°	180°	10 to 12 Minutes
				(Total Time)		
Duckling		10	375°	180°	10 to 12 Minutes	
Turkey Breast		10	325°	180°	10 to 12 Minutes	
Seafood	Fish Fillets or Steaks		12	400°		
	Lobster Tails		13	350°		
	Shrimp		10	350°		

Grill Rack Cooking

OPERATION

- Place the food on the Grill Rack and place the Grill Rack on the Glass Turntable.
- **DO NOT USE THE METAL TRAY**
- On 2X models touch CONVECTION pad, then set temperature to 400°
- On 4X models touch the GRILL pad, then the temperature is automatically set at 400° when you touch the GRILL pad.
- Set time using the cooking chart shown below.
- No pre-heating required.
- Food cooks evenly on both sides, no need to turn.
- Dripping fall on the glass turntable which can be cleaned in the dishwasher.
- Remove food or carry Grill Rack to the counter top. When carrying to the counter top, place a dish under the rack to catch drippings.
- Let the Glass Turntable cool before removing it for cleaning.

COOKING TIME FOR 2X MODELS

Food item	Quantity	1	2	3	4
Hot Dogs		7:00	8:00	9:00	10:00
Steak, Med	(10 oz. each)	15:00	17:00	16:00	19:00
Steak, Well	(10 oz. each)	17:00	19:00	20:00	21:00
Hamburgers	(7 oz. each)	17:00	19:00	20:00	21:00
Chicken Breast	(8oz. each)	20:00	22:00	24:00	26:00



COOKING TIME FOR 4X MODELS

Food item	Quantity	1	2	3	4
Hot Dogs		3:00	4:00	5:00	6:00
Steak, Med	(10 oz. each)	6:00	10:00	11:00	12:00
Steak, Well	(10 oz. each)	10:00	12:00	13:00	14:00
Hamburgers	(7 oz. each)	9:00	10:00	11:00	12:00
Chicken Breast	(8oz. each)	12:00	14:00	16:00	18:00



MICROWAVE COOKING GUIDE

1. Use cooking chart below. In microwaving the greater the quantity, the longer the cook time.
2. Microwaving does not brown food, used High Speed mode to brown, bake and roast.
3. Use a microwave safe plastic, glass or oven safe plastic containers. **DO NOT USE METAL.**
4. When using microwave plastic containers be sure the oven is cool. If the oven is still hot from convection High Speed cooking use a glass or oven safe plastic container.
5. Covered utensils must have venting. Be careful when uncovering.
6. Oven automatically cooks at the HIGH power (10). To set power levels 9-1 press the ADD TIME pad twice and enter a single digit 9-1.

Food		Cover	Power	Time/Min	Comments
Appetizers	Party mix 2 ½ Qts.	No	High (10)	6 to 7	Stir every 2 min.
	Meatball, small meat or hot dog chunks (24)	Wax paper or plastic wrap	High (10)	5 to 6	Spread in a single layer in 2 quart glass dish
	Stuffed Vegetables (12)	No	High (10)	3 to 4	Space evenly on tray or on plate lined with paper towels
	Toasted nuts or seeds (½ to 1 cup)	No	High (10)	8 to 10	Combine nuts with small amount of butter Stir every 2 min.
Cakes	Rectangular, square or round	No	Med. High (7)	5 to 7	
	Cheesecake (9 inch cake or pie plate)	No	Med. High (7)	12 to 14	Microwave cheese cake mixture in 2 quart casserole until thick and smooth Stir every 2 min. with wire whisk Pour into crumb crust - Chill until firm
Eggs Cheese Dairy	Scrambled eggs	No	High (10)	1 min. / egg	Stir 2 to 3 times during microwaving
	Quiche	No	Med. High (7)	16 to 21	Pour filling into pre baked shell
	Thickened sauces & gravies (1 cup)	No	Med. (5)	3 to 5	Melt fat, stir in flour and salt, microwave 1-2 min. Stir to blend, add additional liquid - Stir every min.
	Scald Milk (½ cup)	No	Med. (5)	5	
	Melt Butter (½ cup)	No	High 1 to 2		
	Softened cream cheese (8 oz.)	No	Low (3)	1/2 to 1	
Fish & Shellfish	Filets or steaks (1 lb.)	Wax paper	High (10)	5 to 7	
	Whole Shrimp	Yes	High (10)	10 to 12	Cover with water
	Shrimp Peeled (1 lb.)	Yes	High (10)	6 to 7	Brush with garlic butter before cooking
Fruits	Baked apples or pears		High (10)	2 to 4 / piece	Pierce fruit or peel to prevent bursting
	Baked dried fruits	Yes	High (10)	7 to 8 / lb.	Add ½ Cup water, wine or juice per lb.

MICROWAVE COOKING GUIDE

Food		Cover	Power	Time/Min	Comments
Meat	Brown Ground Beef (1lb)	Yes	High (10)	5 to 7	Break up and stir every 2 min.
	Bacon	Paper Towel	High (10)	1- 1 ½ /slice	Place on paper towel lined plate.
	Sausage Patties, links	Paper Towel	High (10)	1-2 each	Place on paper towel lined plate or glass dish, Turn. Turn over after ½ cooking time.
	Sandwiches	Paper Towel	High (10)	1 to 2	Wrap sandwich in paper towel or napkin.
	Meat Casseroles / raw meat and vegetables	Yes	High (10)	13 to 18	Rearrange or stir after ½ cooking time.
Rice & Pasta	1 cup raw Rice	Yes	High (10)	10 to 12	Ad water to package directions. Stir at ½ cooking time. Let stand covered 5 min. - Fluff with fork
	Instant Rice	Yes	High (10)	2 to 4	Let stand cover 3 to 5 min. - Fluff with fork.
	Long pieces Spaghetti ½ lb. (2-3 quart dish)	Yes	High (10)	12 to 15	Start with very hot water, Stir ½ way through
Vegetables	Asparagus 1 lb.	Yes	High (10)	8 to 10	Place in dish with tender tips toward center Add ¼ cup water
	Green Beans 1 lb. snapped	Yes	High (10)	6 to 8	Add ¼ cup water
	Broccoli, 1 lb. (pieces)	Yes	High (10)	5 to 7	
	Cabbage, 1 small (chopped)	Yes	High (10)	8 to 10	Cover with water in casserole dish.
	Carrots, 2 cup, sliced or baby carrots	Yes	High (10)	5 to 7	
	Cauliflower	Yes	High (10)	5 to 7	
	Corn on the Cob	Yes	High (10)	2-2 ½ / ear	Place in covered dish or wrap in Saran Wrap.
	Sugar Snap Peas ½ lb.	Yes	High (10)	3 to 5	
	Potatoes Boiled	Yes	High (10)	10 to 12 / lb.	Add ½ cup water, ½ t. salt
	Spinach (fresh) 4 cups	Yes	High (10)	3 to 4	Wash, cook with water sill on leaves
	Squash, Acorn, Butternut	No	High (10)	5 to 7	Cut in half, cook cut side down
	Sweet Potatoes, whole	No	High (10)	4-6 / Potato	Wash and pierce before cooking. Let stand for 5 min.
	Zucchini, ¼ in. slices	Yes	High (10)	3-4 / cup	

HEATING & REHEATING GUIDE:

1. Cover foods with paper towel or wax paper to prevent "popping or splattering.
2. When reheating a plate of food place larger pieces on the outside of the plate and smaller pieces in the center of the plate

Food		Amount	Power	Time/Min	Comments	
Appetizers	Saucy such as meatballs, riblets, cocktail franks, etc. ½ cup serving	1-2 Servings	High (10)	2 to 3		
		3-4 Servings	High (10)	5 to 6		
	Dips: cream or process cheese	½ cup 1 cup	Med. (5) Med. (5)	2 ½ to 3 3 to 4	Cover sauce appetizers with wax paper Do not cover pastry	
	Pastry bites, small pizzas, egg rolls etc.	2-4 Servings	High (10)	2 to 3		
Plate of Leftovers	Meat plus 2 vegetables	1 plate	High (10)	2 to 4	Cover plate with plastic wrap or wax paper	
Meats & Main Dishes	Saucy Main Dishes				¾ - 1 cup per serving	
	Chop suey, spaghetti, cream chicken	1-2 servings	High (10)	3 to 6		
	Chili, stew, macaroni & cheese	3-4 servings	High (10)	9 to 12		
	Thin sliced roast meat					3-4 oz. per serving
	Rare, Minimum Time	1-2 servings	Med. H (7)	1 to 3		
	Medium Rare Maximum Time	3-4 servings	Med. H (7)	2 to 4		
	Well done beef, pork, ham, poultry, etc.	1-2 servings	Med. H (7)	1 to 3	3-4 oz. per serving	
		3-4 servings	Med. H (7)	2 to 5		
	Steaks, chops, ribs, other meal pieces:					3-4 oz. per serving
	Rare beef steak	1-2 servings	Med. H (7)	1 to 3		
		3-4 servings	Med. H (7)	2 to 5		
	Well done beef, chops, ribs, etc.	1-2 servings	Med. H (7)	2 to 3		
		3-4 servings	Med. H (7)	5 to 7		
Hamburgers or Meat loaf	1-2 servings	High (10)	1 to 2	4 oz. servings		
	3-4 servings	High (10)	2 to 4			
Chicken Pieces	1-2 servings	High (10)	½ to 1			
	4-4 servings	High (10)				
Hot dogs & sausages	1-2 servings	High (10)	1 ½ to 2 ½			
	3-4 servings	High (10)				

HEATING & REHEATING GUIDE:

Food		Amount	Power	Time/Min	Comments
Pasta & Rice	Plain or buttered	1-2 Servings	High (10)	1 to 3	<i>½ to 1 cup serving</i>
		3-4 Servings	High (10)	3 to 5	
	Topped or mixed - sauce	1-2 Servings	High (10)	1 to 3	
		3-4 Servings	High (10)	3 to 5	
					Tip: Cover saucy main dishes / plastic wrap Cover other main dishes & meats / wax paper Do not cover rare or medium rare meats.
Sandwiches	Moist filling: Sloppy Joe, Barbecue, ham salad in bun.	1-2 Servings	Med. H (7)	1 to 2	<i>1/3 cup servings</i>
		3-4 Servings	Med. H (7)	3 to 4	
	Thick meat-cheese filling / bread.	1-2 Servings	Med. H (7)	1 to 3	Tip: Use paper towel to cover sandwiches
		3-4 Servings	Med. H (7)	3 to 5	
Soup	Water based	1-2 Servings	High (10)	1 to 3	<i>1 cup servings</i>
		3-4 Servings	High (10)	3 to 6	
		1 10 oz. can	High (10)	3 to 5	
	Milk based	1-2 Servings	Med. H (7)	1 to 2	<i>1 cup servings</i> Tip: cover soups / wax paper or wrap
		3-4 Servings	Med. H (7)	6 to 10	
		1 10 oz. can	Med. H (7)	6 to 8	
Vegetables	Small pieces peas, beans, corn, etc.	1-2 Servings	High (10)	1 to 3	Tip: Cover vegetables for most even heating
		3-4 Servings	High (10)	2 to 3	
		1 16 oz. can	High (10)	2 to 4	
	Large places or whole Asparagus spears, corn on the cob, etc.	1-2 Servings	High (10)	2 to 3	
		3-4 Servings	High (10)	3 to 4	
		1 16 oz. can	High (10)	4	
	Mashed potatoes, squash, pumpkin, etc.	1-2 Servings	High (10)	1 to 3	
		3-4 Servings	High (10)	4 to 5	
	Sauces	Dessert chocolate butterscotch	½ cup	High (10)	
1 cup			High (10)	2 to 3	
Meat or main dish, chunky type Giblet-gravy, Spaghetti sauce, etc.		½ cup	High (10)	1 to 2	
		1 cup	High (10)	2 to 3	
		1 16 oz. can	High (10)	3 to 4	
Creamy Type		½ cup	High (10)	1 to 1 ½	
		1 cup	High (10)	2 to 2 ½	

HEATING & REHEATING GUIDE:

Food	Amount	Power	Amount	Comments	
Bakery	Cake, coffee, doughnuts, sweet rolls, nut or fruit bread	1 piece	Low (3)	½ to 1	Tip: Baked goods will feel cooler on the outside, but are warmer on the inside
		2 pieces	Low (3)	1 to 1 ½	
	9 inch cake	1	Low (3)	2 to 3	
	Sweet rolls or doughnuts	12	Low (3)	2 to 3	
	Dinner rolls or muffins	1	Med. (5)	¼ to ½	
		2-4	Med. (5)	1/2 to 1	
		6-8	Med. (5)	1 to 1 1/2	
	Pie, fruit, nut or custard	1 slice	High (10)	½ to 1	
		2 slices	High (10)	1 to 2	
		9-in pie	Med. H (7)	5 to 7	
Griddle	Pancakes, French toast or waffles -plain, no topping	1	High (10)	½ to 1	
		2	High (10)	1 to 2	
		3	High (10)	1 to 2	
Beverages	Coffee, tea, cider, other water based Individual cups	1 cup	High (10)	1 to 2	<i>Stir well before serving</i>
		2 cups	High (10)	1 ½ to 3	
		3 cups	High (10)	2 to 4	
	Coffee, tea, cider, other water based Pitcher or measuring bowl	4 cups	Med. H (7)	3 to 6	
		6 cups	Med. H (7)	6 to 9	
	Warm Milk		Med. H (7)	1 ½ to 2	

DEFROSTING GUIDE

1. Use Speed Defrost for most items. For large cuts of meat use DEFROST BY WEIGHT.
2. Medium to large food items should be turned over after ½ the Defrosting time.
When defrosting several food items frozen together, for example chicken pieces, chops or steaks, separate items after ½ the defrosting time.

Food		Time/Min	Comments
Breads Cakes	Bread or Buns (1 lb. pkg)	5	Turn over after ½ the defrosting time
	Coffee cake (11 to 13 oz.)	5 to 6	
	Sweet rolls (12 oz. pkg)	3 to 4	
	Doughnuts (1-3)	2/4 to 1 ½	
	Doughnuts - glazed (box of 12)	3 to 4	Turn over after ½ the defrosting time.
	French Toast (2 slices)	1 to 2	
	Cake, frosted 2 to 3 layer (17-22 oz.)	3-3 ½	Let stand 10 min. before serving
	Cake, filled or topped 1 layer (12 ½ - 16 oz.)	2 to 3	Let stand 10 min. before serving
	Pound cake (11 ¼ oz.)	3	Let stand 10 min. before serving
	Cheesecake, plain or fruit top (17-19 oz.)	3 to 4	Let stand 10 min. defrost 2-3 min. more if needed
Cupcakes (1 to 2)	½ to 1		
Pies	Fruit or nut pie (8 in.)	9 to 12	Let stand 5 minutes before serving
	Cream or custard pie (14-24 oz.)	2 to 5	Let stand 5 minutes before serving
Fish & Seafood	Filets (1 lb.)	9 to 11	Place unopened package in oven - If fish is frozen in water, place in cooking dish Turn over after first half of time - Let stand 5 minutes on counter to complete defrosting
	Steaks (6 oz.)	3	Place unopened steak in oven - Turn over after first half of time
	Whole fish (8 to 10 oz.)	2 to 7	Place fish in cooking dish. Turn over after first half of time - After second half time, rinse cavity with cold water to complete defrosting
	Shellfish, small pieces (1 lb.)	6 to 10	Spread shell fish in single layer in baking dish - Rearrange after ½ of the time
	Shellfish, blocks, crab meat - (6 oz. pkg.)	2 to 5	Place blocks in casserole. Turn over and break up with fork after first half of time
	Oysters (12 oz. can)	12 to 14	Place block in casserole - Turn over and break up with fork after first half of time Let stand 10 minutes after defrosting
	Scallops (1 lb. pkg.)	12 to 14	Place block in casserole - Turn over and break up with fork after first half of time Let stand 10 minutes after defrosting

DEFROSTING GUIDE

Food		Time/Min	Comments
Seafood	Shellfish - Large Crab Legs 1-2 (8 to 10 oz.)	5 to 10	Arrange in cooking dish with light underside up - Turn over ½ way through
	Lobster Tails 1-2 (6 to 9 oz.)	7 to 14	Arrange in cooking dish with light underside up - Turn over ½ way through
Fruit	Fresh (10 to 16 oz.) (in microwave safe container)	2 ½ to 4 ½	Place package in oven - After ½ defrosting time, break up with fork - Let stand on counter to complete defrosting.
	Plastic Pouch 1 to 2	2 ½ to 8	Place package in oven - After ½ defrosting time - flex package.
Meat	Bacon (1 lb.)	5 to 10 / lb.	Place unopened package in oven - Turn over ½ way through - Defrost just until strips can be separated
	Franks (1 lb.) (½ lb.)	3 to 5 1 ½ to 2 ½	Place unopened package in oven - Turn over ½ way through Defrost just until franks can be separated
	Ground Beef or Pork 1 ½ to 2 lb. 5 lb.	5 to 9 7 to 14 13 to 26	Remove meat softened during defrosting - Set aside - Break up remaining block & continue defrosting
	Roast Beef, Lamb or Veal	7 to 14 / lb.	Place unwrapped roast in glass casserole - Turn over ½ way through and shield warm areas with foil - Let stand 30 min.
	Roast Pork (3-5 lb.)	11 to 22 / lb.	Place unwrapped roast in glass casserole - Turn over ½ way through and shield warm areas with foil - Let stand 30 min.
	Spare Ribs, Pork (1 ½ lb.)	6 to 12 / lb. 8 to 16 / lb.	Place unwrapped roast in glass casserole - Turn over ½ way through and shield warm areas with foil - Let stand 30 min. Place unwrapped roast in glass casserole - Turn over ½ way through and shield warm areas with foil - Let stand 30 min.
	Steaks, Chops or Cutlets	5 to 10	Scrape off meat that softens during defrosting - Set aside - Break up remaining block & continue defrosting
	Sausage, Bulk (1-lb, Roll)	2 to 4 ½	Turn over ½ way through
	Sausage Link (½ to 1 lb.)	2 to 5	Turn over and separate ½ way through.
	Sausage Patties (12 oz. pkg.)		
Poultry	Chicken cut up	10 to 18	Place chicken in oven - After half of defrosting time separate pieces and place in cooking dish - Continue defrosting
	Chicken, whole (2 ½ to 3 ½ lb.)	12 to 24	Place chicken in oven - After half of defrosting time turn over - Shield warm areas with foil - Continue defrosting
	Cornish Hen	6 to 11 / lb.	Place chicken in oven - After half of defrosting time shield warm areas and ends of legs with foil - Continue defrosting
	Duckling	6 to 10 / lb.	Place duckling in oven - After half of defrosting time turn over and place in cooking dish - Shield warm areas and ends of legs with foil - Continue defrosting
	Turkey Breast	5 to 9 / lb.	Place turkey breast, breast side down, in cooking dish - After half of defrosting time, turn breast side up and shield any warm areas with foil - Continue defrosting.

Manufacturer's Limited Warranty

Half Time Oven, Inc. warrants this oven against defects in material or workmanship for a period of one year from the date of its original purchase by a consumer for home use. No other company involved in the sale or promotion of this product is a co-warrantor of this manufacturer's warranty

HOW TO OBTAIN SERVICE

The Oven cannot be returned to the Seller for repair. It must be repaired by an authorized Service Agent. You can get the name and phone number of your nearest service agent by calling 1-800-330-9707. You must take Counter-top Models to the nearest Service Agent to obtain service. Only Built-in ovens or Over the Range Models will be serviced in-home.

EXCLUSIONS

MANUFACTURER'S OBLIGATION UNDER THESE WARRANTIES SHALL NOT EXTEND TO ANY MALFUNCTION OR OTHER PROBLEM CAUSED BY:

- | | |
|--|---|
| <ol style="list-style-type: none">1. Damage unless attributable to a defect in material or workmanship.2. Unreasonable use or misuse, such as, but not limited to, improper setting of controls, improper electrical supply and improper installation.3. Damages resulting from or problems caused by any installation, repair, alteration, modification, or adjustment of the appliance not performed by an Authorized Service Agent. | <ol style="list-style-type: none">1. THESE WARRANTIES DO NOT COVER:
The replacement of light bulbs or metal trays.2. Ovens purchased or used for commercial purposes. |
|--|---|

LIMITATION OF LIABILITY

In no event shall the manufacturer be liable for any incidental or consequential damages (*including, but not limited to food loss*) or for any special damages or any further loss as a result of any breach of these warranties. Some states do not allow the exclusion or limitations of consequential damages; so the above limitations or exclusion may not apply to you.

TO SECURE WARRANTY SERVICE

Before requesting service, be sure that you have read and followed all procedures in the Use and Care Book. Should service be required call 1-800-330-9707 for the name and number of your nearest service agent. If your oven is installed in a Recreational Vehicle you can call 1-800-772-7262. Evidence of purchase date must be provided to obtain warranty service.

If you are not satisfied with the response to your service requirements, write
Service Department,
P.O. Box 6066, West Palm Beach, FL 33405

The letter should include the date of purchase and details concerning your problem.

HOW TO OBTAIN OUT OF WARRANTY PARTS

You may purchase **OUT OF WARRANTY PARTS** or **ACCESSORIES** by calling **1-800-330-9707**.

ADDITIONAL RIGHTS

These warranties are the only written or expressed warranties given by the manufacturer. No one is authorized to increase, alter, or enlarge the manufacture's responsibilities or obligations under these warranties. These warranties give you specific legal rights, which may vary, from state to state.

THIS WARRANTY COVERS PRODUCTS IN THE UNITED STATES AND CANADA ONLY